

SSEN Distribution

# YOUR CUSTOMER SERVICE GUIDE



## POWER CUT?

In the event of a power cut, call our 24/7 contact centre.

Just dial 105 to be connected to our team.

**POWER CUT?  
CALL 105**



Scottish & Southern  
Electricity Networks

Powering our  
community



# ABOUT THIS GUIDE

This guide will provide you with the following information:

About us	3
Power cuts and how to prepare for them	4
Power cuts - Be Prepared in advance	5
Priority Services Register (PSR)	6
Fuel Poverty referral information	7
Visiting your home	8
Complaints	9
Our Complaints process	10
Safety and Security of Supplies	11
Contact us	12

# PAGE

# GUIDE SUPPORT

If you need this document, in a different format such as:

- Translated into an alternative language
- Easy Read format
- Large print
- Hard copy
- Audio CD
- Braille

Please contact our Priority Services Team.



Call our Priority Services Team

**0800 294 3259**

Or email us via:

**[networks.priority.services@sse.com](mailto:networks.priority.services@sse.com)**

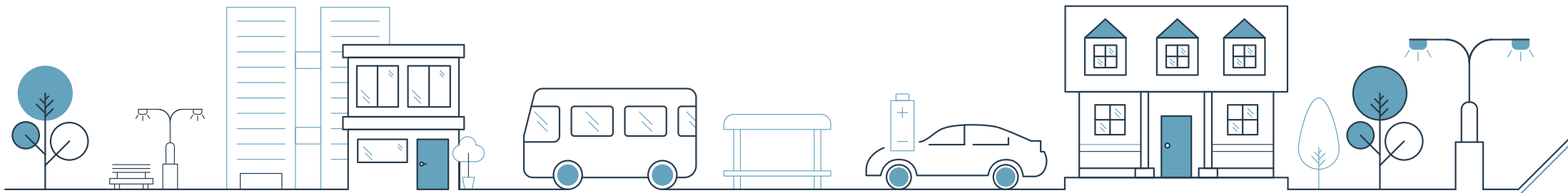



# ABOUT US

We are Scottish and Southern Electricity Networks.

It's our responsibility to manage, maintain and develop the electricity networks which bring power to over 3.9 million homes and businesses in the north of Scotland and central southern England.

It's important to be aware that we are not an energy supplier (the company you pay your electricity bill to).

Our priority is to provide a safe and reliable supply of electricity to the communities we serve in Scotland and England.

## OUR DISTRIBUTION NETWORK AT A GLANCE

Over **3.9million** homes and businesses

Over **128,000km** of overhead lines and underground cables

Over **460km** of subsea cables powering our island communities

Over **4,400** employees across the country

North of Scotland  
SHEPD LICENCE AREA



Central Southern England  
SEPD LICENCE AREA



# POWER CUTS AND HOW TO PREPARE FOR THEM

Keeping your power on safely is our number one priority, and we invest millions every year to upgrade and strengthen our network, however, even with this investment and maintenance, unfortunately there are times when power cuts occur.

On other occasions, we may need to turn your power off for a short time to carry out essential maintenance; when this is the case, we will aim to provide you, where possible, with 30 days' notice if you are a business customer and 7 days' notice if you are a domestic customer.

We will follow this up with a reminder message the day before if we have your telephone number. If for any reason the timescales we have provided you with for a planned outage are not met, we will aim to contact you.

Furthermore, if you are registered on our Priority Services Register, we will aim to call you to ensure you are supported during power cuts.

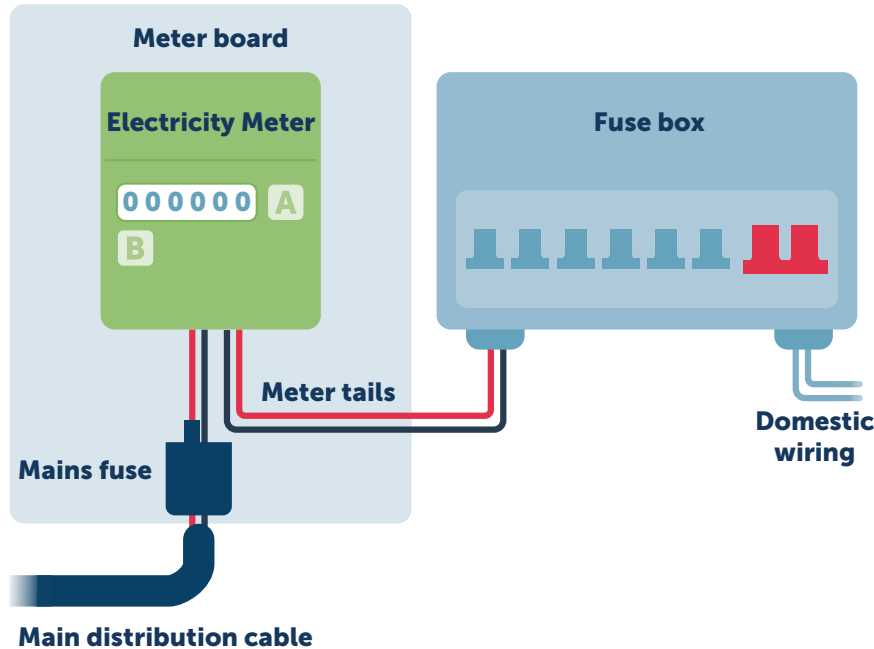

## RESPONSIBILITY - COLOUR KEY

- Homeowner / Landlord**  
A qualified electrician can support you with this and any internal wiring
- Electricity Supplier**  
This is maintained by your electricity supplier
- SSEN Distribution**  
Equipment provided by your distribution network operator (DNO)

\* For illustration purposes, meters, cables and colours will vary

### Main distribution cable

The cable that we maintain to your property, which brings the your electricity from the grid.

*referred to as: distribution cable, mains cable*

### Mains fuse

We install the main cutout fuse, which protects your property in the event of a power surge.

*referred to as: cutout, main fuse*

### Meter tails

These are the cables between the meter and your fuse box.

*referred to as: meter cables*

### Electricity Meter

This is either a smart meter or standard meter. This is provided by your electricity supplier. They are the company who sends your electricity bills.

*referred to as: supply meter*

### Fuse box

This is an important electrical device, it protects electrical appliances from damage and you from electrical shock.

*referred to as: consumer unit, fuse box, fuse panel*

### Meter board

This is a wooden board which your supply meter is mounted to and is screwed to the wall.



# POWER CUTS - BE PREPARED IN ADVANCE

Whether you have to stay in or get out, packing a small emergency kit will help you get through. Keep it in a safe place at home where you can reach it easily. Your kit should be kept in a waterproof bag if possible, and the top recommended items to include are:

## Things to consider



If you rely on medical equipment/aids reliant on electricity, check to see if it can work with a battery or if it can operate manually. If not, have a plan in place so that you know what to do in the event of a power cut.



If you rely on oxygen, ensure that you have back up cylinders and you have the number for your healthcare professional or oxygen supplier handy to call if you need more.



Traditional style telephones that plug directly into the telephone socket in the wall will work during a power cut.



Switch off appliances and lights but leave one light on. So you know when power has been restored.



Don't open the freezer door unless you have to. This helps food stay frozen for longer. When the power comes back on, check the food inside. Food should keep for about 8-12 hours without power. Always check your manufacturer's manual to make sure.



If you have elderly or vulnerable neighbours, check to make sure they are comfortable.



If we have warned you in advance that the electricity will be turned off, boil some water and keep it in an insulated flask.

## Be Prepared - Pack an Emergency Kit



## Essential

- Bottled water and non-perishable foods** (inc. Baby food/pet food)
- First aid kit** (and essential medicines)
- Radio and Torch** (spare batteries or wind-up equivalent)
- Identity documents** (passports/drivers licence)
- Change of clothes** (inc. warm jumpers and blankets)
- Mobile phone charger** (ideally a portable charger)

## In addition

- Money (change, cash and card)**
- Spare keys for house and car**
- Copies of insurance policies and birth certificates**
- Spare glasses/contact lenses**
- Notebook, pen/pencil**



# PRIORITY SERVICES REGISTER

We know that a power cut can be worrying or difficult, that's why we offer free extra help and support. We can help you far better, and quicker, if we know in advance what extra support you might need.

## You can sign up if you



Are dependent on electricity for home medical care



Have a chronic illness or short term medical condition



Are disabled



Have special communication needs



Are blind or partially sighted



Deaf or hard of hearing



Have children under 5



Are over 60 years old



Require assistance for another reason, even if temporarily

Of course, everyone has different needs so feel free to contact us to discuss your requirements.

## What our Priority Services offers you

- ✓ During severe weather events and prolonged power outages, we will do everything we can to keep you informed about when supply is likely to be restored and what help we may be able to provide. You will receive regular power cut updates 24 hours a day.
- ✓ Our Priority Services line is available 24 hours a day. We'll contact you, or your nominated contact, if we need to switch off your power to carry out essential maintenance.
- ✓ When requested, we'll offer you advice on how to prepare for a power cut in a format that suits your needs, e.g. Braille, textphone, audio CD, Easy Read or in another language.
- ✓ We work with local authorities, emergency services and agencies, like British Red Cross, to provide extra support to people on our Priority Services Register.
- ✓ During severe weather events and prolonged power outages, we will do everything we can to keep you informed about when supply is likely to be restored and what help we may be able to provide.
- ✓ Our connection to local welfare vehicles help us in our aim to provide meals, drinks, warmth and charging points for those who need them.
- ✓ We offer a service where you can agree a password to use when dealing with our employees. That way we can look after your personal safety and home security.
- ✓ You can nominate a friend or family member that we can contact regarding Priority Services and power disruptions on your behalf.
- ✓ Energy suppliers also provide Priority Services. When you register with us, we will share your details with your energy supplier.

## Contact our Priority Services team today



Priority Services web page  
[ssen.co.uk/psr](https://ssen.co.uk/psr)



Priority Services Email  
[networks.priority.services@sse.com](mailto:networks.priority.services@sse.com)



Priority Services helpline  
**0800 294 3259**



# ENERGY EFFICIENCY HELP

If you wish we can arrange free expert energy advice for you from our partners YES Energy Solutions, this includes:

- A free introductory energy saving pack in the post with gadgets to help you reduce your bills.
- Top tips to save money by reducing your energy use.
- Assessments on your eligibility for grant schemes to improve the efficiency of your home.
- Income maximisation checks to ensure you're claiming all the benefits and financial support you're entitled to.
- Mental, physical and wellbeing support.
- Support and advice for choosing or installing low carbon technologies in your home.
- YES Energy Solutions' services are free and confidential.



## Fuel Poverty referral support

Call us free or you can complete our online form here



Fuel Poverty Advice  
**0800 294 3259**



Online Help and Advice  
**[ssen.co.uk/yes](https://www.ssen.co.uk/yes)**



## Did you know?

Many people miss out on money that there to help such as the Warm Home Discount, Cold Weather Payment or other available schemes.



# VISITING YOUR HOME

Our teams work directly with communities, helping customers on the phone or occasionally visiting you in your home. It is important that you feel safe in your home and have confidence that our teams are skilled and trustworthy.

## Our Standards for visiting your home

We want our customers to know that our employees are “fit and proper” and have a minimum set of standards that define this.

All our employees and contract partners will:

- Show their identity cards on arrival and always explain the reason for their visit.
- Be clean, tidy, polite and respectful.
- Have relevant checks done to ensure they act with integrity and honesty.
- Have an understanding of customer processes and policies, including identifying and supporting customers in vulnerable situations.
- Be able to communicate professionally and clearly with customers/stakeholders at all levels in a variety of situations, including in customers homes, schools and pre-arranged events.
- Use social media professionally and in line with our internal processes and policies.
- Have the competence, skills and experience necessary for their role.

## Set up a password for peace of mind

To provide you with extra reassurance that any visits from our employees are genuine, you can set up a password in advance at any time. Then whenever we visit, whether or not we have been able to arrange an appointment, our employees will use the password.

Our employees can also provide you with contact details for help and advice on the safety and security of your electrical supply if they are not able to answer any enquiry themselves.

We may use contractors to carry out work, if this is the case we expect them to work using the same procedures, principles and ethics maintained by SSEN employees.

If you are unsure that a caller is genuine, do not let them into your home. If you are in doubt call us on



Call to ID Check  
**0800 015 5170**



To set up a password please contact us



Direct password  
**0800 048 3516**





# COMPLAINTS

All our employees are highly trained to offer you the best possible customer service and will do their best to help you. They will ensure the matter is resolved as quickly and easily as possible.

## How to raise a complaint

We've made it as easy as possible for you to contact us with a complaint.

- 1 Contact us**  
We need to know how we can help you. You can reach us by phone, email or through our webform.
- 2 We will help**  
We will attempt to resolve your complaint within the initial call. Where that is not possible we will follow the Ofgem approved industry standard complaints process (please see page 10).
- 3 If you need further support**  
If we cannot find a solution or resolve your complaint we will provide guidance to what you can do next.

## About the Energy Ombudsman

The Energy Ombudsman service is a free and fair service that helps solve problems with your energy company or your local distribution network operator (DNO).

## POWER CUT?

In the event of a power cut, call our 24/7 contact centre.

Just dial 105 to be connected to our team.

**POWER CUT?  
CALL 105**





## Our contact details

-  Call our complaints team  
**0800 980 1395**
-  Online complaints form  
**[ssen.co.uk/complaints](https://ssen.co.uk/complaints)**
-  Email our complaints team  
**[customercomplaints@ssen.co.uk](mailto:customercomplaints@ssen.co.uk)**

Full contact details are available on our Contact page (please see page 12).

## Energy Ombudsman contact

-  Website  
**[energyombudsman.org](https://energyombudsman.org)**
-  Helpline  
**0330 440 1624**



# OUR COMPLAINTS PROCESS

We will log your complaint and attempt to resolve matters for you as quickly as possible. Our complaints process is explained below:

## SSEN DISTRIBUTION COMPLAINT PROCESS

**Day 1**

### INITIAL CONTACT

You can raise a complaint with us by phone, email, post or even online and a member of our dedicated complaints team will be happy to help.

When you call us with a problem, our staff will attempt to resolve matters there and then. If you email or write to us, we aim to resolve matters within 2 working days. We may call you to do this.

**Day 4**

### SSEN COMPLAINTS TEAM

If you're still unhappy after our initial contact with you, we'll spend the first 4 days trying to find a resolution for you.

During this time the business resolver for your area will be involved every day and will ensure all options have been considered to resolve your complaint as quickly and effectively as possible.

**Day 4 - 31**

### EXECUTIVE COMPLAINTS TEAM

If the complaint is still unresolved after 4 days, we will pass the complaint to our Executive Complaints Team.

Our Executive Complaints Team are a specialist team who will spend time to look into your complaint and see if there's something they can do to help find a resolution.

**8 Weeks**

### INDEPENDENT REVIEW/ MUTUAL RESOLUTION

If your complaint reaches 8 weeks, it will automatically be independently reviewed. When your complaint reaches this stage, you have the right to approach the 'Ombudsman Services: Energy', for further guidance and they will review your case.

During this time, we will continue to work with you to reach mutual resolution however if we are unable to resolve your complaint to your satisfaction, a final offer or deadlock letter will be sent and you can again approach 'Ombudsman Services: Energy', to have your case reviewed by them. 'Ombudsman Services: Energy' are there to resolve disputes between consumers and companies, their service is free and impartial.

**Day 31+**

### SENIOR MANAGER REVIEW

If after 31 days, you're still unhappy with what we've done, a senior manager or Head of Business Area will review your complaint.

The senior manager or Head of Business Area will work with you to find a suitable resolution and if you're still unhappy, will discuss the next steps for you. This is the final internal stage of our Complaints Handling Process.

Key



You/our customer



Us/SSEN Distribution

All time scales are expected to be discussed and agreed with customers and therefore may vary depending on circumstances.



# SAFETY AND SECURITY OF SUPPLIES

Our priority is to provide you with a constant, reliable supply of electricity. Sometimes things like severe weather can impact your electricity supply but be assured that we'll always work as quickly as possible to restore your power.

## Safety and Security of Supplies

If you have any questions regarding the maintenance of the security, availability or quality of service of the electricity network or would like to report anything in relation to the electricity network that you feel we should be aware of or could be unsafe, please contact us. For example, you could contact us if you have problems with your power supply, such as flickering lights, or if you see damage to an electricity overhead cable or substation.

You can keep track of your local supply status here:

[ssen.co.uk/powertrack](https://ssen.co.uk/powertrack)

or you can download our free Power Track app which allows you to easily report a problem with your power and report damage to our network. All reports of damage or power cuts are processed in a prompt and efficient manner.

## Performance Standards

Our industry has Guaranteed Standards of Performance for restoring power and providing other services, such as keeping appointments.

If we don't meet any of these standards, we are required to pay our customers compensation. For example, if your electricity supply fails because of a problem in our network during normal weather conditions, we must restore it within 12 hours of first becoming aware of the problem. If we are unable to restore it in this time, we will make payments within our Guaranteed Standards of Performance guidelines. Other standards apply in more extreme weather events or circumstances.

The Guaranteed Standards specify exactly who is entitled to receive compensation and how much this compensation will be. You can find a copy of the Guaranteed Standards at

[ssen.co.uk/about-ssen/performance-standards](https://ssen.co.uk/about-ssen/performance-standards)



# CONTACT US

## POWER CUT?

Call the short dial power cut number

 **CALL 105**

Our power track website and app

 Report and track a fault  
**powertrack.ssen.co.uk**

## PRIORITY SERVICES



Priority Services direct  
**0800 294 3259**



Priority Services web page  
**ssen.co.uk/psr**



Priority Services Text phone  
**0800 316 5457**



BSL InterpreterNow  
**ssen.co.uk/bsl**



Priority Services Email  
**networks.priority.services@sse.com**

## COMPLAINTS



Call our complaints team  
**0800 980 1395**



Online complaints form  
**ssen.co.uk/complaints**



Email our complaints team  
**customercomplaints@ssen.co.uk**

## OUR ADDRESS



### North of Scotland office

Customer Relations  
Scottish and Southern Electricity Networks  
Inveralmond House, 200 Dunkeld Road  
Perth  
PH1 3AQ



### Central Southern England Office

Customer Relations  
Scottish and Southern Electricity Networks  
4 Penner Road  
Havant  
PO9 1QH

## WEB AND SOCIAL MEDIA



Our main website  
**ssen.co.uk**



Twitter  
**@ssencommunity**



Facebook  
**/ssencommunity**



Whatsapp  
**0734 202 8546**

## YOUR DATA

SSEN need to know your basic personal data such as your address to be able to maintain and operate the electricity distribution networks for which we are responsible. In particular, we need to know your basic personal data like name, address and contact details to direct your enquiries to the correct SSEN team, to allow our engineers to visit you onsite where required and to provide assistance to you in the case of an emergency. We may also have your special category personal data (for example, details of your health conditions) if you have signed up to be on our Priority Services Register. On the basis of protecting adults and children at risk, we also share this with energy suppliers, local authorities operating resilience support, and water suppliers in England. To learn more about how we manage your data you can read our privacy notice [ssen.co.uk/privacy-notice](https://www.ssen.co.uk/privacy-notice)

Scottish and Southern Electricity Networks is a trading name of: Scottish and Southern Energy Power Distribution Limited Registered in Scotland No. SC213459; Scottish Hydro Electric Transmission plc Registered in Scotland No. SC213461; Scottish Hydro Electric Power Distribution plc Registered in Scotland No. SC213460; (all having their Registered Offices at Inveralmond House 200 Dunkeld Road Perth PH1 3AQ); and Southern Electric Power Distribution plc Registered in England & Wales No. 04094290 having their Registered Office at No.1 Forbury Place 43 Forbury Road Reading RG1 3JH which are members of the SSE Group